

Installation and Service Instructions

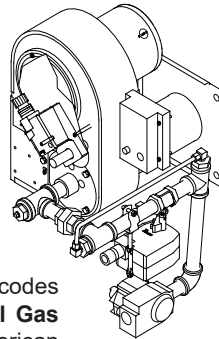

Domestic: ANSI Z21.17
Canada: CSA2.7



Economite RE4400DS HTD Gas Burner

★ MADE in the USA ★

- **In the United States**, installation must conform with local codes or in the absence of local codes, with the **National Fuel Gas Code**, ANSI Z223.1-latest edition available from American National Standard Institute. Further reference should be made to the recommendation of your fuel supplier.
- **In Canada**, installation must conform with local codes or in the absence of local codes, with Installation **Codes for Gas Burning Appliances and Equipment**, CGA Standard CAN/CGA 1-B-149.1 or 2. Further reference should be made to the recommendation of your fuel supplier.
- **WARNING:** Additions, changes, conversions and service must be performed by an authorized Midco representative, service agency or the fuel supplier. Use only MIDCO specified and approved parts.
- **INSTALLER:** Inform and demonstrate to the user the correct operation and maintenance of the gas utilization equipment. Inform the user of the hazards of storing flammable liquids and vapors in the vicinity of this gas utilization equipment and remove such hazards. Affix this manual and associated literature to the burner.

CODE COMPLIANCE IS THE SOLE RESPONSIBILITY OF THE INSTALLER.

- **USER:** Retain this manual for future reference. If other than routine service or maintenance as described in this manual and associated literature is required, contact a qualified service agency. **DO NOT ATTEMPT REPAIRS.** An inadvertent service error could result in a dangerous condition.

FOR SERVICE CONTACT

Name: _____

Address: _____

Phone: _____

Date of Installation: _____



Midco®
INTERNATIONAL

Midco® International Inc.
4140 West Victoria Street
Chicago, Illinois 60646
toll free 866.705.0514
tel 773.604.8700
fax 866.580.8700

web www.midcointernational.com
e-mail sales@midcointernational.com

AVOID ERROR IN PARTS SELECTION. When ordering use complete MIDCO Part Number and Description. Furnish Burner Model Number, Bill of Material Number and Serial Number (if available) from the specification plate found on the product.

IMPORTANT: Availability of parts as well as specifications are subject to change without notice. Please consult factory for item availability.

SAFETY INFORMATION TERMS: The following terms are used to identify hazards, safety precaution of special notations and have standard meanings throughout this manual. They are printed in all capital letters using a bold type face as shown below, and preceded by the exclamation mark symbol. When you see the safety alert symbol and one of the safety information terms as shown below, be aware of the hazard potential.



DANGER: Identifies the most serious hazards which will result in severe personal injury or death.

WARNING: Signifies a hazard that could result in personal injury or death.

CAUTION: Identifies unsafe practices which would result in minor personal injury or product and property damage.



WARNING: If the information in these instructions is not followed exactly, a fire or explosion may result, causing property damage, personal injury or death.

Do not store or use gasoline or other flammable vapors and liquids in the vicinity of this or any other appliance.

WHAT TO DO IF YOU SMELL GAS:

- Do not try to light any appliance.
- Do not touch any electrical switch; do not use any phone in your building.
- Immediately phone your gas supplier from another building. Follow the gas supplier's instructions. If you cannot reach your gas supplier call the fire department.

Installation and service must be performed by a qualified installer, service agency or the gas supplier.

AVERTISSEMENT. Assurez-vous de bien suivre les instructions données dans cette notice pour réduire au minimum le risque d'incendie ou d'explosion pouvant entraîner des dommages matériels, des blessures ou la mort.

Ne pas entreposer ni utiliser d'essence ni d'autres vapeurs ou liquides inflammables à proximité de cet appareil ou de tout autre appareil.
QUE FAIRE SI VOUS SENTEZ UNE ODEUR DE GAZ:

- Ne pas tenter d'allumer d'appareil.
- Ne touchez à aucun interrupteur. Ne pas vous servir des téléphones se trouvant dans le bâtiment où vous êtes.
- Appelez immédiatement votre fournisseur de gaz depuis un voisin. Suivez les instructions du fournisseur.
- Si vous ne pouvez rejoindre le fournisseur de gaz, appelez le service des incendies

L'installation et l'entretien doivent être assurés par un installateur ou un service d'entretien qualifié ou par le fournisseur de gaz.

BURNER MODEL: _____

BILL OF MATERIAL NUMBER: _____

SERIAL NUMBER #: _____

WIRING DIAGRAM: _____

As an ISO 9001:2008 certified company, we proudly design, manufacture and assemble our products in Chicago, Illinois, USA.

Quality Designed for Proven Performance



718
8471 50
Printed in USA

Specifications and Part I - Installation

Specifications

The **ECONOMITE Model RE 4400DS HTD (High Turn Down)** burners with direct spark ignition are adaptable to most gas utilization equipment.

AIR DELIVERY (Approximate Air Delivery at Zero Draft)		
RE4400DS HTD	87 SCFM ¹	
FIRING RATE (NATURAL) ² (Based on 0 draft over fire pressure)		
MAXIMUM MBH ³ 400		
MINIMUM MBH ³ 20		
GAS SUPPLY PRESSURE REQUIRED		Min Max
250 MBH	7.0" to 14.0" W.C.	
350 MBH	7.0" to 14.0" W.C.	
400 MBH	7.0" to 14.0" W.C.	
TUBE DIAMETER	4"	
RECOMMENDED COMBUSTION CHAMBER SIZE (AT MAX. BTU/HR)		
WIDTH	10"	
LENGTH	16.5"	
ELECTRICAL SUPPLY ⁴	120/208/230 VAC.....	60 Hertz
ELECTRONIC CONTROL VOLTAGE	24 VAC	
FLAME SAFETY....Direct Spark Ignition of Main Flame, Electronic Safety		

Table 1: Burner Specifications

1. SCFM = Standard Cubic Feet / Minute.
2. All Ratings Based on 1000 BTU/Cu. Ft. NATURAL Derate burner for altitude over 2,000 feet by 4% for each 1,000 feet above sea level.
3. 1 MBH = 1,000 BTU/hr.
4. Burners available in 115V, 208V or 230V power supply. Consult burner name plate for correct power supply, or as recommended by the equipment manufacturer.

I Part I Installation Combustion Chamber

- The burner tube, or the stainless steel sleeve that is included with the burner, must be sealed air tight into the combustion chamber opening with refractory material. The sleeve is preferred as it is designed to properly locate the end of the tube relative to the inside wall of the combustion chamber, and to permit burner removal or as recommended by the equipment manufacturer.

⚠ CAUTION: In no case should the burner tube be allowed to extend into the chamber because high combustion chamber temperatures will cause premature electrode, burner tube and sleeve deterioration.

II Electrical

⚠ CAUTION: Refer to wiring diagrams in Figure 1A and 1B or located on the burner housing.

Installation wiring and grounding to the burner must conform to local codes, or, in their absence in the **United States to National Electric Code, ANSI/NFPA No. 70 latest edition; in Canada, to Canadian Electrical Code Part 1, CSA Standard C22.1**

- Use copper wire not less than 14 gage for line voltage wiring. Hook up to a dedicated line with an on-off disconnect switch and a minimum 10 Amp breaker, or as required by equipment manufacturer.
- The frame of the burner should be well grounded. A ground lug is located in control box for positive grounding where insulated pipe couplings are used or where any doubt exists regarding grounding sufficiency.
- Confirm that the polarity is correct—hot wire to strip terminal L1, neutral L2—and that the neutral line is not subject to induced low voltage (check L2 to earth ground) from other equipment, as that can cause the Electronic Control to malfunction.
- Each installation must include suitable limit control(s).

⚠ CAUTION: Label all wires prior to disconnection when servicing controls. Wiring errors can cause improper and dangerous operation. Verify proper operation after servicing.

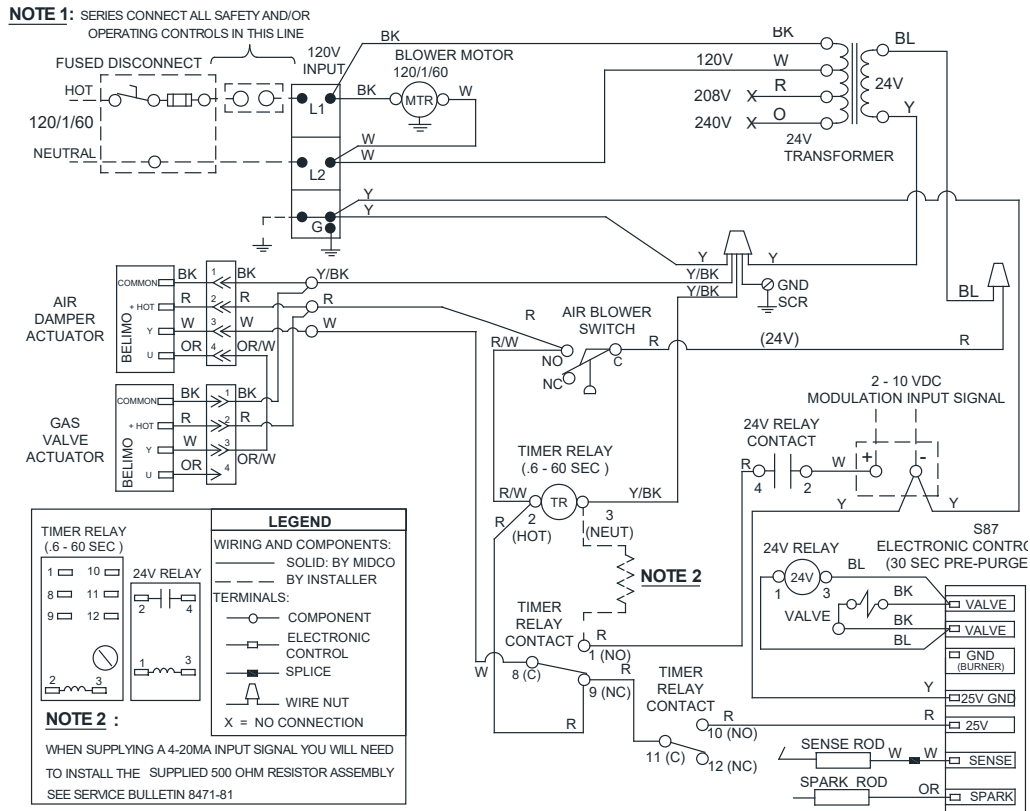

Figure 1A
 Wiring Diagram RE 4400DS HTD (120 V)

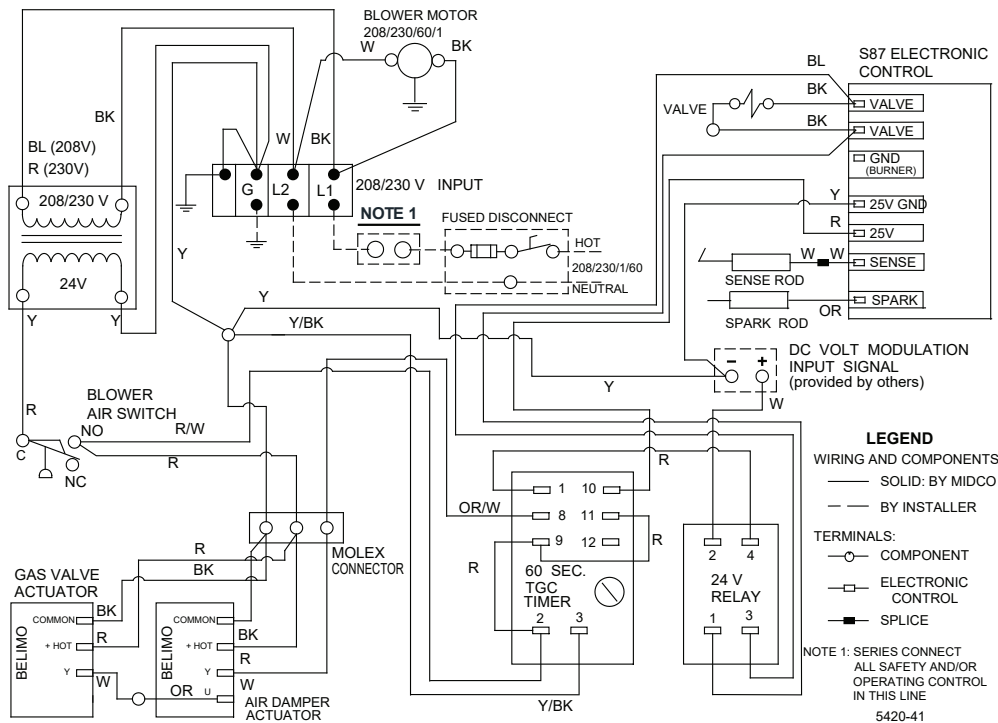

Figure 1B
 Wiring Diagram RE 4400DS HTD (208/230 V)

Part I - Installation

III

Piping

CAUTION: The available gas pressure should be within the limits shown in Table 1 - SPECIFICATIONS section. Excessive pressure may damage electric valves, regulators and manual valves. If the supply pressure exceeds the 14.0" W.C. maximum, a suitable high pressure regulator must be installed between the Main Manual Shut-Off Valve and burner combination valve.

- The burner gas supply piping should branch off from the main line as close to the gas meter as possible. Do not connect to the bottom of a horizontal section. Use new black pipe and malleable fittings free of cutting and threading burrs or defects.
- Piping must also comply with your local codes.
- To obtain the maximum firing rate of the burner, the gas supply piping must be sized to provide a minimum pressure of 7.0" W.C. (Natural) for 400 MBH to the inlet of the combination redundant valve when the burner and all other gas utilization equipment are on refer to Table # 3 for 350 MBH and 250 MBH gas pressure requirements. The main regulator, if equipped, should be mounted upright and in a horizontal run of pipe, refer to regulator manufacturer's installation instructions.

CAUTION: Because it is difficult to accurately control pressure during supply pipe leak testing, it is recommended that all low pressure 1/2 PSIG (14.0" W.C. max.) components be disconnected during testing. Exposing low pressure regulators and valves, including manual valves, to pressures over 1/2 PSIG (14.0" W.C.) will cause damage and void all warranties.

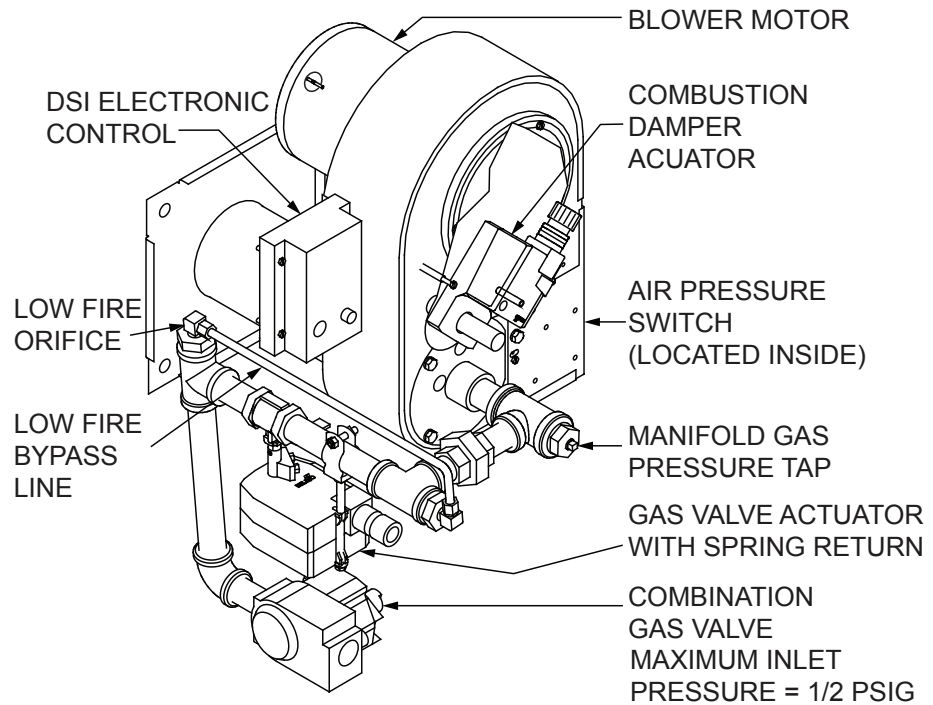

Figure 2 -
Typical Piping Diagram

⚠ DANGER: Explosion hazard.
Do not use oxygen for pressure testing.
An explosion could occur during initial start up.

- If the burner piping must be rearranged because of space limitation, be sure to carry out the general arrangement shown in Figure 2. Install the combination valve in any position except up-side down.
- When the burner is installed in the vestibule of jacketed equipment, it is recommended that the Automatic Safety Shut-Off Valve be left adjacent to the burner within the vestibule and the Main Manual Shut-Off Valve be installed outside.

- Run full size pipe or tubing from regulator vent openings to outside of building. Refer to regulator manufacturer's installation instructions. Provide no traps in the vent lines and terminate away from all doors and windows; also make provisions for keeping rain and foreign objects from entering the vent piping.
- When high supply gas pressure is encountered, as in the case in many industrial plants, the gas line size can be reduced to allow for a greater pressure drop; however, the size must be sufficient to deliver burner rating pressure.

⚠ CAUTION: High gas pressure supply lines require the proper pressure reducing regulators. Install a high pressure regulator of the Tight Shut-Off type, sized for main gas input, upstream of the low pressure regulators.

- The high pressure regulators must be adjustable to 14" W.C. outlet pressure.
- When the gas supply line is about to be put into service it must be tested to insure that it is gas tight. Use air or inert gas under pressure and test with soap and water to locate leaks.
- Before gas is turned onto the system, a check must be made to see that there are no open fittings and to make sure the burner main valve is closed.

Natural Gas capacities shown are for a total pressure drop of 0.3" W.C. For 0.5" W.C. pressure drop, multiply capacity shown by 1.3. For higher permissible pressure drops, consult your gas supplier.

Pipe Size	Type of Gas	Approximate Capacity -MBH				
		Pipe Length				
		10	20	40	75	100
3/4	Natural	200	150			
1	Natural	400	275	200	150	
1 1/4	Natural			450	325	275
1 1/2	Natural			650	475	400

Table 2 - Schedule 40 NPT Pipe-Capacity Chart

NOTE: If there is more than 1.0" W.C. differential in the inlet pressure to the burner compared to when all other gas utilization equipment are off, refer to Section VII.

Burners are approved for use with NATURAL gas and should be used only with the gas specified on the rating plate.

- The gas input should be set at the heating rate determined by the building heat loss and/or heating plant survey, but not exceeding the rated maximum input of the gas utilization equipment or Economite burner.

⚠ WARNING: Ignition is automatic. Make spark observations into combustion chamber only with Main Manual Shut-Off Valves closed. Confirm that gas utilization equipment does not contain any accumulated gases. Purge as described in step 3 below.

⚠ CAUTION: Cover plates, guards, and enclosures must be maintained in place at all times except during maintenance and service.

1. Check the burner piping and valves for gas leaks by applying a weak liquid soap solution to unions and joints with the gas supply on. Leakage will be indicated by the appearance of soap bubbles. Locate and correct all gas leaks before proceeding.

⚠ WARNING: DO NOT USE OPEN FLAME.

Part I - Installation

V Initial Startup /Adjustment Continued

2. Purging the air from the gas supply line at this step will expedite first light-off.
IMPORTANT: Purge outside the building. Do not purge into the gas utilization equipment.
3. To purge the gas utilization equipment and chimney of any accumulated gases, turn main Manual Gas Cock OFF, turn burner power on, and set operating control to ON or thermostat to call for heat. Let the blower run long enough to accomplish four combustion chamber volume air changes, but not less than five minutes.

Natural Gas Pressure Settings RE4400DS HTD (High Fire Settings)

Natural Gas	
Input	Manifold ¹ Pressure
MBH	(" W.C.)
400	4.5
350	3.5
250	1.8

Table 3 - Capacity and Preliminary Gas Settings
DATA FOR TABLE IS APPROXIMATE AND BASED
ON "0" OVERFIRE PRESSURE AT SEA LEVEL

¹. Adjust the main regulator to vary the manifold gas pressure and burner input within the range shown. Do not exceed pressure as listed in Table 3, under any circumstances. Use combustion readings (CO and O₂) and a flow meter to determine exact inputs.

CAUTION: Make sure that the capacity range of the burner, manifold pressure, and the preliminary combustion air shutter setting are suitable for capacity rating of the gas utilization equipment. Refer to Section V and Table 3.

WARNING: Repeated unsuccessful attempts to light will result in accumulated gases in gas utilization equipment and chimney. To prevent these gases from reaching an explosive level, periodically purge the gas utilization equipment and or chimney as described in step 3 above.

4. To make a preliminary setting of the burner input, determine the manifold gas pressure required from Table 3 and adjust the Main Gas Pressure Regulator on the combination gas valve accordingly.
5. To determine the firing rate for NATURAL gas, accurately time test dial for the number of seconds for one revolution and use the following formula. All other gas utilization equipment must be off.

$$\frac{3600 \times \text{test dial size} \times \text{BTU value}}{\text{No. of seconds for one rev. test dial}} = \text{BTU/Hr.}$$

Then divide by 1,000 for MBH value.

Example:
$$\frac{3600 \times 1 \times 1000}{10} = 360,000 \text{ BTU/Hr or } 360 \text{ MBH}$$

6. Check the operation of the burner; start and stop it several times with the thermostat or operating control.
7. With the burner running, check the operation of all limit and associated controls.
8. Perform the following final adjustments for combustion and flue gas temperature. Take the flue gas samples and temperature immediately ahead of the draft control or as specified by the equipment manufacturer.
 - A. Reset gas input, if necessary, to adjust stack temperature.
 - B. Make the final setting of the combustion air shutter by checking the flue gases with a combustion testing instrument. The carbon monoxide content should conform to local codes, or in their absence, to the level specified in the United States or Canadian Standard referenced on the front cover of this manual or within the limits prescribed by local codes.
9. Check the draft control, if equipped with one, to make sure there is no spillage of flue products into the room.

- ⚠ DANGER:** Do not tamper with the unit or controls. If trouble occurs contact the installing contractor, service agency, fuel supplier or equipment manufacturer. See front cover.
- ⚠ DANGER:** Be sure that the main Shut-Off Valve is closed and the burner power supply is turned off before removing any parts for service.
- ⚠ CAUTION:** Cover plates, guards, and enclosures must be maintained in place at all times except during maintenance and service.

CARTRIDGE ASSEMBLY

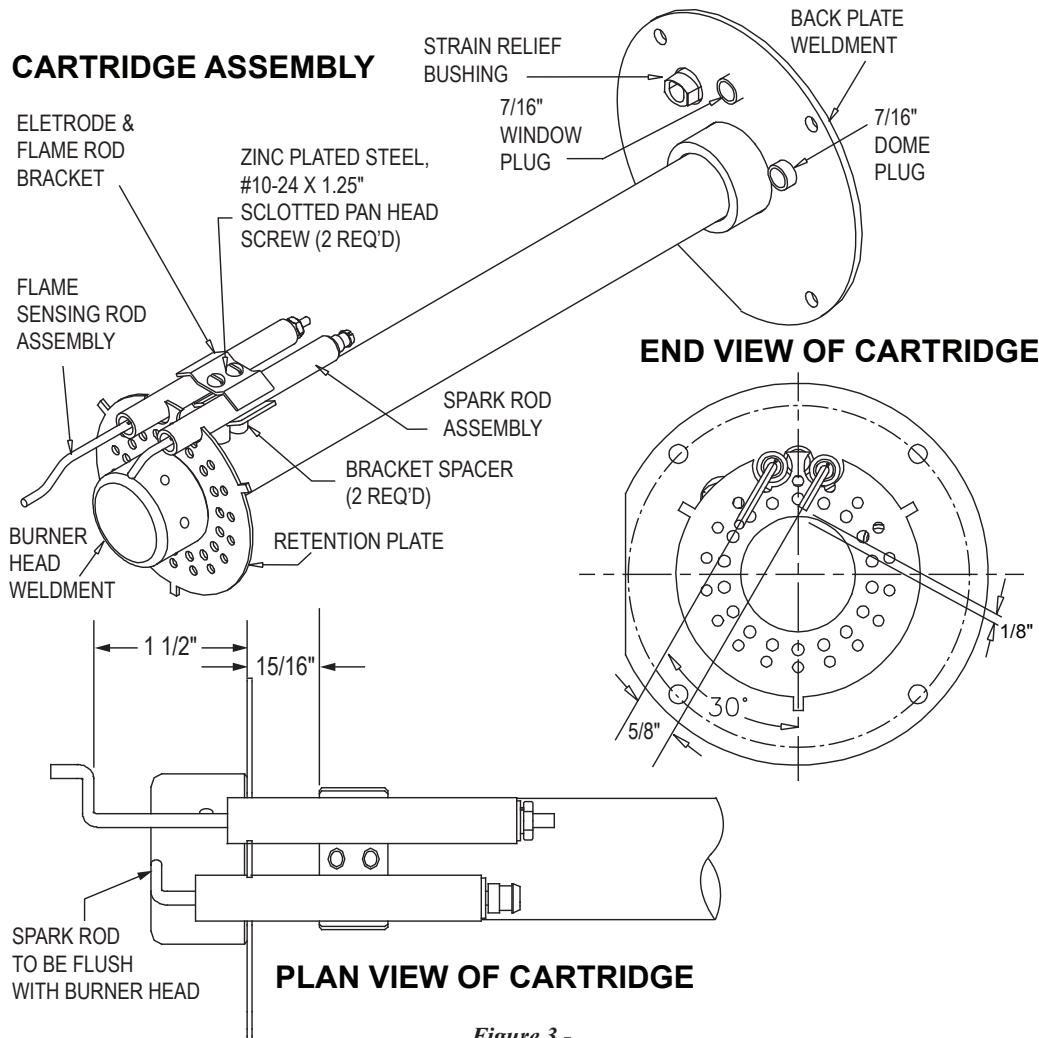

PLAN VIEW OF CARTRIDGE

Figure 3 -

General Assembly for the RE4400DS HTD

- The flame sensing rod must be positioned as shown in Figure 3 so that the Electronic Control will detect a proper flame.
- Both the spark and flame rods are current carrying conductors and, along with their connecting wires, must be kept free of contact with conductive metal parts of the burner. Rod insulators and wire insulators should be clean, dry and free of cracks.
- Both the spark and flame rods are made from heat resistant alloys and can be expected to have a long service life. They should be routinely inspected, however, for corrosion or loss of metal.

- Should replacement or service be required, valve manufacturer's instructions must be followed as outlined in their information sheet.
- Outlet pressure settings must be checked while the gas is flowing.
- To adjust outlet pressure, remove the seal cap for access to the adjusting screw. Turning the screw clockwise will increase outlet pressure, counter clockwise will decrease outlet pressure.

VI Electrodes

VII Valve Train

Part II - Service

VIII *Sequence of Operation*

- The Midco RE4400DS is supplied with two timers to provide high fire purge and low fire start. With power applied to L1 and L2 the blower motor starts. Once the blower motor starts the blower air switch closes. 24 Volt power is applied to the air damper actuator and prepurge timer. The air damper actuator begins to open the air damper to provide a high fire purge. After 45 seconds the air damper actuator begins to close. 24 Volt power is then applied to the Honeywell S87K DSI Ignition control module. The S87K DSI Ignition control module also provides additional prepurge for 30 seconds. Once the S87K DSI Ignition control module completes its prepurge 24 volts is applied to the Combination gas valve and internal ignition transformer. If flame is proven (minimum 2 DC Micro amps) the burner will continue in the run mode. The 2 to 10 Volts DC temperature control will then begin to modulate the air damper actuator to provide the proper combustion air for the burner. The feedback signal from the air damper actuator will drive the spring return gas valve actuator to provide the correct gas flow for the burner. Refer to Table 3 for the correct maximum fire manifold pressure settings.

If the burner lights and then loses the DC micro Amp flame signal it will retry to ignite after completing an additional prepurge cycle. If the burner fails to reignite power will need to be turned off and reapplied after 30 seconds.

For startup information see Section X.

IX *Electronic Control*

- The S87K is a low voltage, solid state, direct spark ignition control module for gas-fired furnaces, boilers and heating appliances. UL Listed models are only available with a prepurge timer. The S87K controls the gas valve, monitors the main burner flame and generates a high voltage for spark ignition.

- The S87K uses separate electrodes for spark ignition and flame sensing. Includes a 30 second (minimum) delay for use with system pre-purge.

- For operation characteristics, maintenance, and service procedures, refer to manufacturer's literature provided with burner, or contact your Honeywell dealer.

X *Start Up*

- Startup instruction for RE 4400DS HTD

1. Set the operating control to off or thermostat below room temperature.
2. Turn manual gas cock on.
3. Turn burner power on.
4. Set operating control to ON or thermostat to call for heat. Wait 75 seconds, if the burner has failed to light, or if burner lights then goes out, the system will go into safety lockout. De-energize the system by setting operating control to off or thermostat below room temperature for at least 30 seconds to reset the system. Repeat step 4 for restart.
5. The Belimo Actuator controls the firing rate of the burner by providing a signal to terminal 3 on the actuator. The actuator has stops (set screws), which have been pre-set to 20 MBH (0.02" W.C. manifold pressure, 2 Volts DC signal input) at low fire and 400 MBH at maximum fire (4.5" W.C. manifold pressure, 8 Volts DC signal input) at zero back pressure. The regulator on the combination valve has been set to high fire and should not need to be adjusted. The "Modulating Gas Valve" (butterfly valve which is attached to the spring return actuator) will vary the amount of gas flow into the burner.
6. The low fire bypass and the Modulating Gas Valve are pre-set by the factory for a minimum firing rate of 20 MBH. The flame signal at this firing rate should be above 2 DC micro amps.
7. Check the modulation tracking by modulating the burner to 4 Volts DC signal. The manifold pressure should be approximately 0.8" to 0.9" W.C. If not, loosen the 7/16" nut on the Modulating Gas Valve Actuator and make necessary adjustment with the green handle of the butterfly valve (see Figure 4). Retighten the nuts and modulate the burner to low fire (2 Volts DC) and back up to 4 Volts DC again to check the adjustments. If the manifold pressure is not as specified, repeat step 7 again.
8. The damper should be flush with the low fire stop. The O₂ concentration of the flue exhaust at the low fire rate should be approximately 10% +/-2. To adjust the O₂ level at low fire (allow more air or reduce the air), vary the alignment between the damper and the inlet ring. Minimum air shutter adjustment can be done by adjusting the three 8-18 screws on the inlet ring (see Figure 5). To increase or decrease the O₂ percentage substantially loosen the air damper from the shaft and make necessary adjustment. Check combustion readings to verify burner performance.

**Figure 4 -
Valve Train Assembly
RE4400DS HTD**

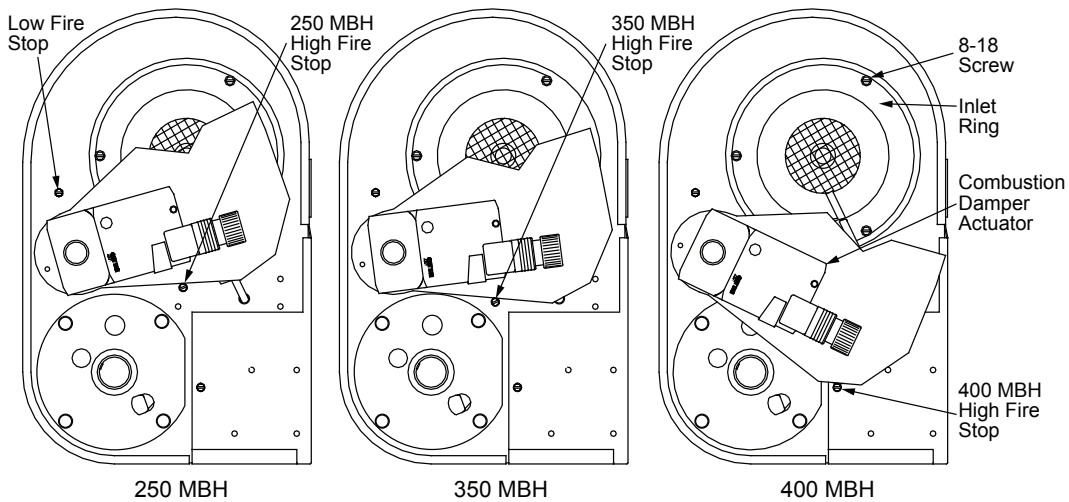
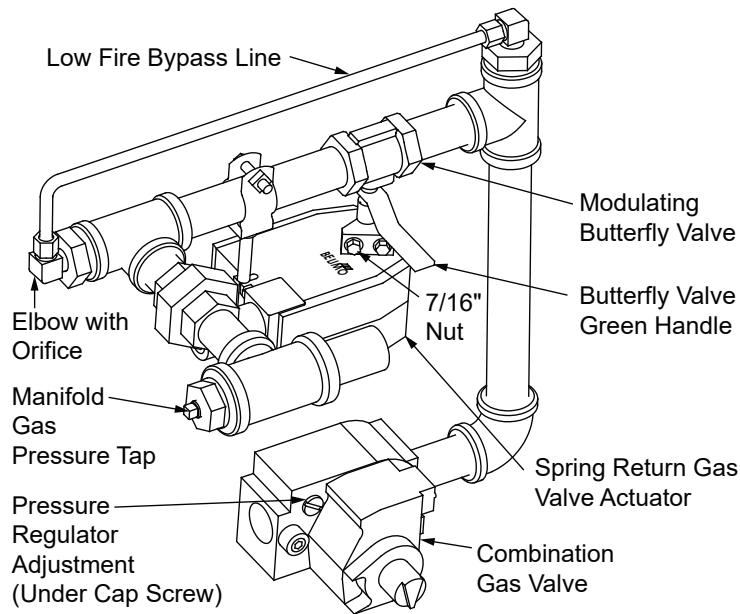

**Figure 5 -
Damper Location at High Fire Firing Rate - 250 MBH, 350 MBH and 400 MBH
RE4400DS HTD**

Special equipment, either factory or contractor installed, may cause variation in the procedures and descriptions given in this manual.

Consult the OEM's manual to identify the differences in the information.

Keep for your records

Model Number	Purchased from - Name:
Serial Number	Address
Installation Date	City, State, Zip
Bill of Material (BOM) #	

End user will return the burner to the company/ contractor purchased from. No equipment may be returned without written authorization from the purchasing company/ contractor. Returned goods must be shipped prepaid to the purchasing company/ contractor.

⚠ WARNING: Improper installation and use of this product could result in personal or property injury.

FILL OUT THE FORM ON THE LAST PAGES AND RETURN TO PURCHASING COMPANY/ CONTRACTOR

Warranty Midco® International Inc Limited Warranty Policy Exclusions Terms, Customer Requirements and Instructions

Products manufactured by Midco International Inc. (hereinafter Midco) are guaranteed to be free from defects in workmanship and materials, under normal use and service, **for a period of twelve (12) months from the date of installation, or 18 months from date of manufacture or whichever occurs first.**

If a part is defective due to workmanship or materials and the part is removed from the product within the applicable warranty period and returned to Midco in accordance with the procedure described below, Midco will at its option either repair or replace the part. This warranty extends only to persons or organizations who purchase products for resale. The warranty does not cover labor and/ or freight.

The expressed warranty above constitutes the entire warranty of Midco with respect to the products in its publications and is IN LIEU OF ALL OTHER WARRANTIES, EXPRESSED OR IMPLIED, INCLUDING ANY WARRANTY OF MERCHANTABILITY OR WARRANTY OF FITNESS FOR A PARTICULAR PURPOSE. IN NO EVENT SHALL MIDCO BE RESPONSIBLE FOR ANY CONSEQUENTIAL DAMAGES OF ANY NATURE WHATSOEVER.

Instructions for returned goods are as follows: The following will apply to the return of any products to Midco International Inc. under this warranty:

Parts must be:

- Identified with Midco's *Return Authorization Number -(RAN) *(Available only directly from Midco. Contact Customer Service to obtain a tag.) email returns@midcointernational.com
- Protected from shipping damage.
- Received transportation pre-paid at:
Midco International Inc.
Return Goods Dept.
4140 West Victoria Street
Chicago, Illinois 60646-6727
- Found by Midco's inspection to be defective in workmanship or materials under normal use and service.
- Handled in accordance with one of the two following procedures, as specified by the customer making the return:
 - Credit Procedure.** If replacement part was purchased from Midco, credit will be issued at the net price in effect at the time of purchase with presentation of Midco's invoice number and date.
 - Repair or Replacement Procedure.** Midco will, at its option, either repair or replace the part free of charge and return it or its replacement. Midco will pre-pay transportation at the lowest cost. The replacement will be, at Midco's option, either a functionally equivalent new or replacement product. Premium transportation will be used at customer's request and expense.

Note: All Midco burners have a specification plate showing Model, Bill of Material and Serial Number. All three (3) numbers must be shown on your Midco Return Goods Tag. The Serial Number is necessary to determine Warranty coverage. If the Serial Number is beyond the Warranty period, a receipt or invoice showing purchase, delivery or installation date is required.

Final disposition of any warranty claim will be determined solely by Midco. If an inspection by Midco does not disclose any defect covered by this warranty, the product will be returned, scrapped, repaired, or replaced as instructed by the customer. Products returned to the customer will be sent shipping charges collect.

If you have any questions relative to product returns to Midco, call, write or e-mail:

Midco International Inc.
Warranty Returns/Customer Service Manager
4140 West Victoria Street
Chicago, Illinois 60646-6727
tel 773.604.8700
fax 773.604.4070
email returns@midcointernational.com
web www.midcointernational.com



Midco
INTERNATIONAL

★ MADE in the USA ★

As an ISO 9001:2008 certified company, we proudly design, manufacture and assemble our products in Chicago, Illinois, USA.

Midco® International Inc. - 4140 West Victoria Street - Chicago, Illinois 60646 - toll free: 866 705 0514
tel: 773.604.8700 - fax: 866.580.8700 - web: www.midcointernational.com - e-mail: sales@midcointernational.com



718
8471 50
Printed in USA

Warranty

Midco® International Inc Limited Warranty Policy
Exclusions Terms, Customer Requirements and Instructions

Final disposition of any warranty claim will be determined solely by Midco.

If an inspection by Midco does not disclose any defect covered by this warranty, the product will be returned, scrapped, repaired, or replaced as instructed by the customer. Products returned to the customer will be sent shipping charges collect.

Call factory for information (866 705 0514)

Fill out form and fax to 866 580 8700 or copy and mail to:
or email to: returns@midcointernational.com or

Midco International Inc
4140 West Victoria Street
Chicago, Illinois 60646

Date of Purchase _____

End User Name _____

End User Company Name _____

Street & Apt. No. _____

City, State, Zip _____

E-mail Address _____

Web Address _____

Telephone _____

Fax _____

Burner

Parts

Model Number _____

Bill of Material # _____

Serial Number _____

Installation Date _____

Purchased from - Name: _____

Address _____

City, State, Zip _____



FOLD LINE

PLACE
STAMP
HERE

Midco International Inc.

Attn: Warranty Department
4140 West Victoria Street
Chicago, Illinois 60646

FOLD LINE

